

GENERAL SETTING

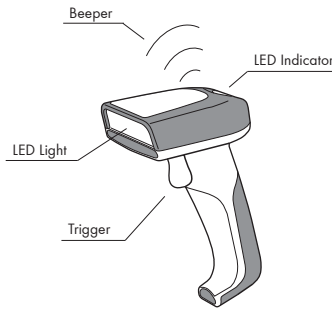

LED Indication

- Off - Ready to scan or No power.
- Blue - Good read.
- Blue&Red - Disconnection or Discoverable

Beeper

- Long Beep - Power up.
- Short Beep - Good read.
- 2 Beeps - Connection or Successful setup.
- 3 Beeps - Disconnection or Error.

Note: The shape of scanner may vary based on configuration.

QUICK CONNECTION

The scanner runs in HID plug & play mode right out of box

Step 1 - Connect the cradle to the host computer

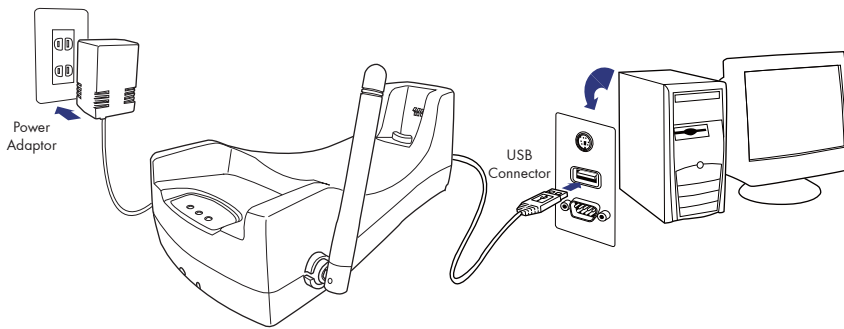

Step 2 - Activate the scanner

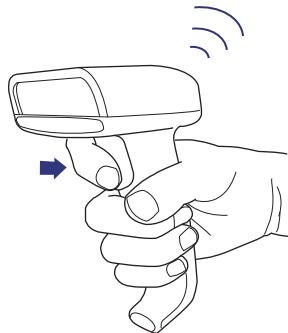

Press and hold the trigger for 1 second until a beep sounds.

Step 3 - Wait for connection

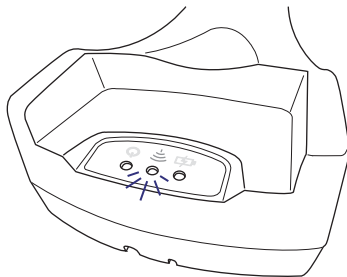

The blue LED indicator on the cradle will turn on to verify a successful connection to the scanner.

! If the cradle fails to connect the scanner, please follow the instruction of **BLUETOOTH CONNECTION OPTIONS** section

LINK QUALITY SETTING



Link Quality (activated by default) ensures a more secure data transmission from the scanner to the cradle/host. To accelerate the transmission speed, you may disable Link Quality, but the data transmission integrity might become less reliable.

.E031\$



DISCONNECT

Scan this barcode before you try to change the bluetooth connection option or when you need to disconnect the scanner from the cradle/host PC.

BLUETOOTH CONNECTION OPTIONS

.E041\$



BT mode - HID plug & play

1. Connect the cradle to the host PC.
2. Scan [DISCONNECT]
3. Scan [BT mode - HID plug & play], and the scanner will emit 8 beeps.
4. Scan the Host Address barcode on the cradle's bottom.
5. The scanner will beep twice and cradle's blue indicator LED will stay on to verify a successful connection.

.E042\$



BT mode - SPP

1. If the host does not support Bluetooth communication, a third-party Bluetooth adaptor is required.
2. Scan [DISCONNECT]
3. Scan [BT mode - SPP], and the scanner will emit 8 beeps.
4. Select "Wireless Scanner" from the discovered device list. The default pincode is "1234".
5. Open serial communication software with proper com port(see Device Manager) and protocols(9600,8,N,1) set up.
6. The scanner will beep twice and cradle's blue indicator LED will stay on to verify a successful connection.

.E043\$



BT mode - HID

1. If the host does not support Bluetooth communication, a third-party Bluetooth adaptor is required.
2. Scan [DISCONNECT]
3. Scan [BT mode - HID], and the scanner will emit 8 beeps.
4. Select "Wireless Scanner" from the discovered device list.
5. The Bluetooth application may prompt you to scan a pincode(see **PINCODE SETUP** section) it generated.
6. The scanner will beep twice and cradle's blue indicator LED will stay on to verify a successful connection.

PINCODE SETUP

.E032\$



Pincode - Start

.E033\$



Pincode - Stop

1. When asked by Bluetooth application to enter a pincode
2. Scan [Pincode-Start]
3. Scan the numeric barcodes according to the pincode generated by the Bluetooth application, and then scan [Enter]
4. Scan [Pincode-Stop]
5. The scanner will beep twice to verify a successful connection.



1



2



3



4



5



6



7



8



9



0



Enter